

INSTALLATION INSTRUCTIONS FOR FREESTYLE LINEAR SPRING U-BRAKES

IMPORTANT:

These top mount brake levers are not compatible with linear pull (V-type) brakes. Only caliper or canti brakes should be used with our top mount levers.

After installation test your brake system at slow speeds before normal use.

If you are unsure about any part the installation and set up of these brake levers, consult a qualified mechanic or our local bike dealer.

It is not liable for damage or injury as a result of improper installation or use.

TOOLS YOU'LL NEED:

4 mm Allen Key – for mounting bolts

A - Remove grip tape

The series are designed to be mounted onto 24 mm, 26 mm, 31.8 mm diameter drop-down handlebars. (This is the thinner part on standard bars.) Remove a few turns of the handlebar grip tape to give access to the bar. The hinged clamp design of the lever allows the lever to be mounted and installed without having to remove more tape or the original brake levers.

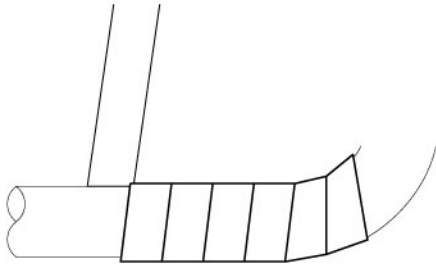

B - Mount lever to handlebar

Open the hinged clamp of the top mount lever by unscrewing the clamping bolt with a 4 mm Allen key. Place the top mount lever on the (Ø24mm) handlebar. Close the hinge clamp and insert the clamping bolt. Before tightening, position and angle the lever to a comfortable and convenient position on the handlebars. Tighten the clamping bolt with a 4 mm Allen key by final tightening torque: 5-7 Nm.

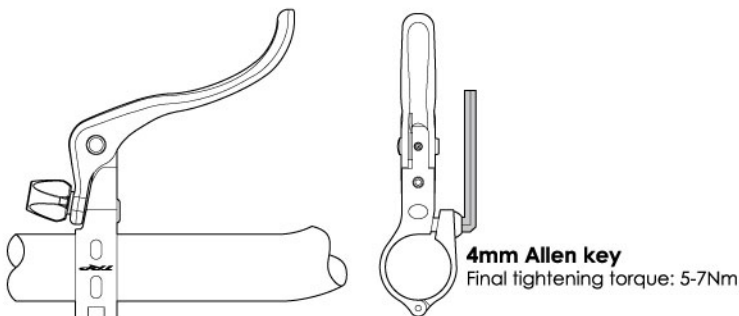

C - Remove cable from brake and housing

Detach the brake cable from the brake as per manufacturer's direction. Remove the brake cable from the cable housing as per the original lever/brake manufacturer's instructions NB. The housing may remain in it's original position inside the handlebar grip tape.

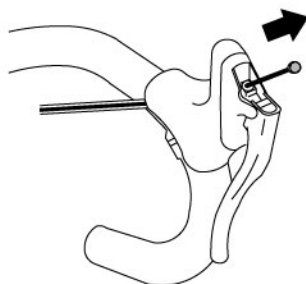

D - Cut housing & insert into lever guides

Cut the cable housing at a position where it reaches the top mount lever clamp on the side that is furthest away from the center of the handlebar. Insert the upper housing end into the housing guide hole on the clamp.

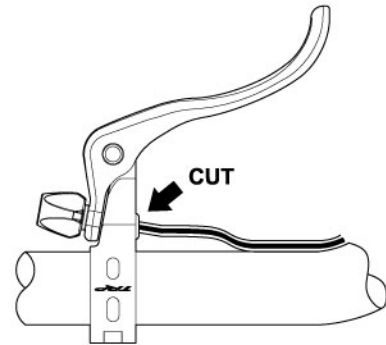

E - Insert cable through housing and levers

Re-insert the original brake cable through from the drop down handlebar lever, through the upper housing and through the hole running through the center of the top mount lever. Slide the cut-off, lower part of the cable housing over the cable and insert the housing end into the adjuster barrel of the top mount lever. The other end of the housing runs to the brake.

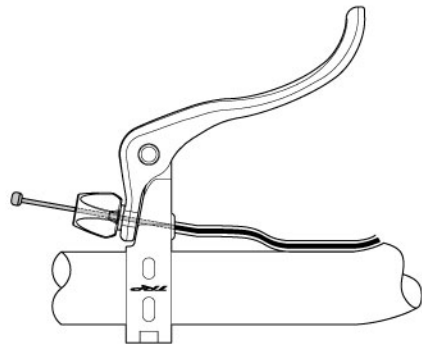

F - Setup brake & retape handlebars

Attach the housing and cable to the brake, and set up the brake according to the manufacturers instructions. Re-wind the grip tape onto the handlebar and secure with tape.

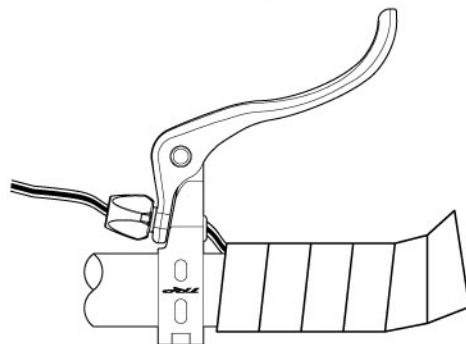

QUESTIONS?

For questions about setup, usage or general inquiries, please e-mail or call toll free at:

TRP Brakes
info@trpbrakes.com
1-877-807-4162
www.trpbrakes.com