

Installation Instructions Cyclocross Cantilever Brakes

NOTE

For Front Wheel

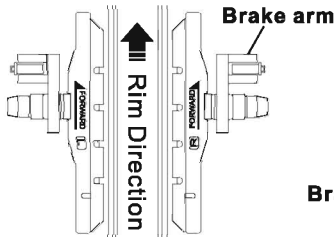

For Rear Wheel

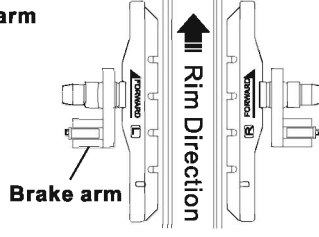

IMPORTANT:

The brakes are not compatible with linear pull brake levers. Only drop-down handlebar/ canti type levers should be used with this brakes.

Warning:

The brakes offer considerable braking power and require practice at slow speeds before normal use.

Warning:

If you are unsure about any part the installation and set up of this brakes, consult a qualified mechanic or your local bike dealer.

TEKTRO is not liable for damage or injury as a result of improper installation or use.

- Clean and grease frame and fork pivot bosses. Slide spring and brake arm onto each pivot, mounting the short end of the spring in the middle spring hole on pivot boss and long end of spring into slot in the brake arm. Thread supplied mounting bolt into pivot boss and tighten to torque of 6-8Nm.

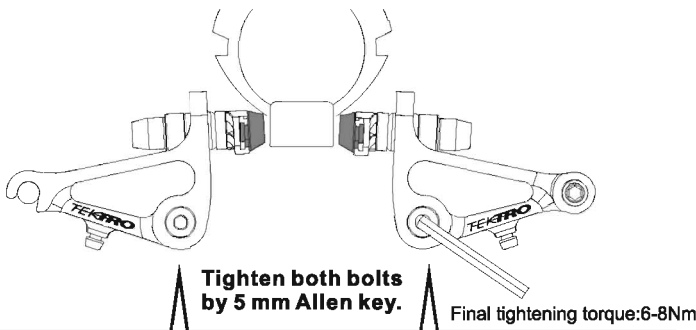

- Rotate each brake arm toward the rim until brake pad contacts the rim. Align each brake pad so inside edge of pad is parallel to the braking surface of the rim. Make sure there is a 1 mm gap between the top edge of the rim and the top of the pad. Holding each arm so the pad is against the rim, use a 5mm Allen wrench to tighten the pad while holding in the proper position relative to the rim. Tighten to a final torque of 6-8Nm.

Tighten both bolts by 5 mm Allen key
Final tightening torque: 6-8Nm

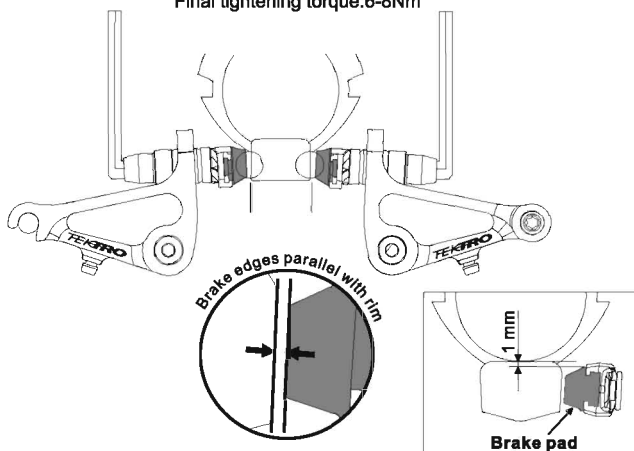

- Thread the brake cable through the center bolt on the straddle cable carrier making sure that there is a minimum of 20mm between the end of the cable housing and the top of the straddle cable carrier. Hold the straddle cable carrier center bolt with a 5mm Allen key and tighten the nut using a 10mm spanner.

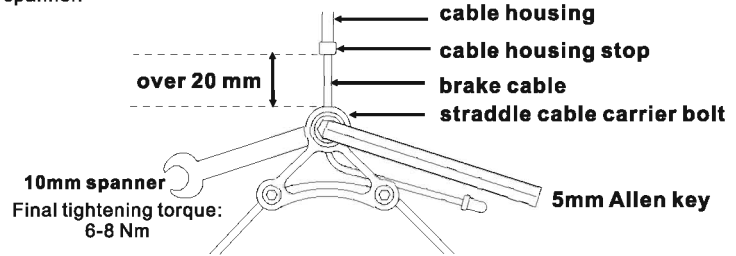

- Slip the straddle cable through the straddle cable carrier and then the under the anchor bolt plate. Hook the fixed end of the cable into the release slot and pull the cable tight until the brake pads contact the rim. Using a 5mm Allen wrench tighten the anchor bolt to a torque of 6-8Nm.

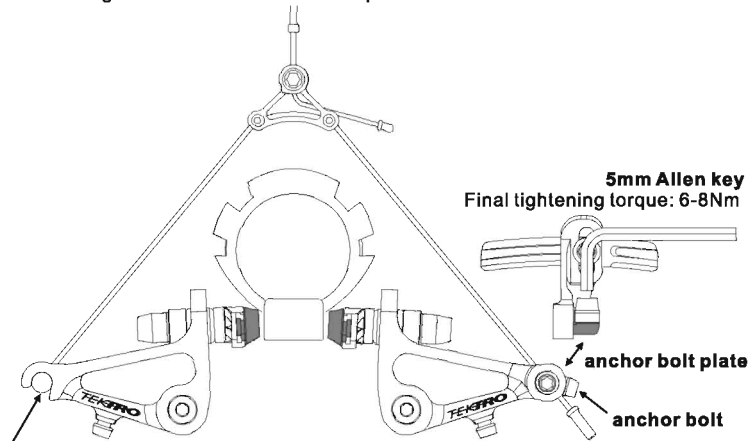

Cable end stop

- Depress the brake lever a few times while checking to see that the tension is equal on both arms. Pad/rim contact should occur simultaneously on each side. If pad contact is uneven, balance the brake arm spring tension by turning the spring adjusters on the brake arms with 3mm Allen wrench. Turning adjuster screw clockwise will increase spring tension, turn anti-clockwise to decrease spring tension.

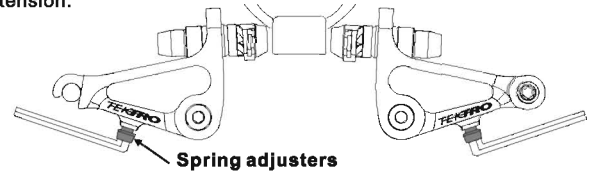

Tension by turning the spring adjusters with 3mm Allen wrench

- Once you have the tension balanced, tighten the 2.5mm Allen bolts on the straddle cable carrier to hold it in position on the straddle cable. Tighten these bolts to 1-1.5Nm.

Tighten both bolts by 2.5 mm Allen key.
Final tightening torque: 1-1.5Nm

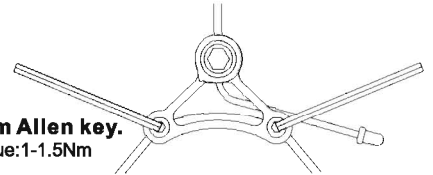

- Trim the cable ends, leaving at least 30mm of cable and crimp on lead caps to keep the ends from fraying.

A note about brake pads, All TEKTRO pads have grooves running up and down on the pad / rim contact surface. Once these grooves have been worn down so they are no longer visible, the pads should be replaced. Continued use past the wear line could result in damage to your rim and inferior braking performance.



TEKTRO
BRAKE SYSTEMS

Website: www.tekro.com E-Mail: info@tekro.com

First Edition - May 2007 Made in Taiwan

000907CR720